

Temperature Monitoring by Wireless Communication at Furnace

- ❑ **Industry:** Steel Mill
- ❑ **Products:** [YTMX580 \(Multi-Input Temperature Transmitter\)](#)
[YFGW520 \(Field Wireless Access Point\)](#)
[YFGW410 \(Field Wireless Management Station\)](#)



❑ Introduction

Electrical Furnaces used at steel mills to heat and melt metals, require a water cooling system to provide consistent and safe heating. If part of the cooling system fails, it can affect the quality of the product and also risk the safety of the facility and the operators.

For steady control, hundreds of temperature sensors can be installed around the furnace. However the sensor wiring is often damaged by the heating environment. The application also generates strong electrical noise which leads to erratic measurements making it difficult to apply proper control.



❑ Proposal

To overcome the challenges associated with severe ambient condition or the presence of strong electrical noise, Yokogawa recommends a Field Wireless solution based on ISA100 Wireless technology.

- Compared with wired data transition with long signal wires, the wireless data transmission is not susceptible to electrical noise.
- Switching to wireless measurement reduces the labor and cost associated with ongoing replacement of wires near the harsh furnace environment.
- Yokogawa's Field Wireless solution provides better data quality for temperature control, reduced maintenance cost and improved product quality as a result of stable temperature control.



YFGW520 (Field Wireless Access Point)
YFGW410 (Field Wireless Management Station)



YTMX580 Multi-Input Temperature Transmitter

□ Features of YOKOGAWA Field Wireless

- YTMX580 is the multi-input temperature transmitter. One unit can support up to eight temperature sensors.
- The data from YTMX580 can be transmitted up 500 meters line of site. Even in dense process piping without direct visibility to the next router, reliable communication of 50 meters can be achieved. These are the benefits of ISA100.11a protocol.
- It is scalable up to 500 wireless units (including routers).
- Coexistence with Wi-Fi: Robust, reliable communication

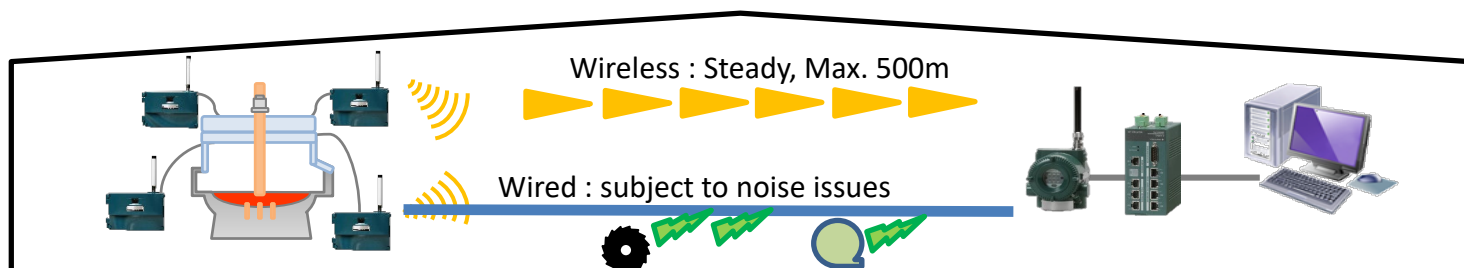

□ Other details of YOKOGAWA Field Wireless

• Redundancy

Reliability of the wireless system is ensured by redundant wireless channels and devices. Redundancy achieves high-speed switching.

• Cyber security

With a variety of security functions including device authentication, message authentication, message freshness checks, and encryption, the field wireless network is protected from multiple types of cyber attacks.

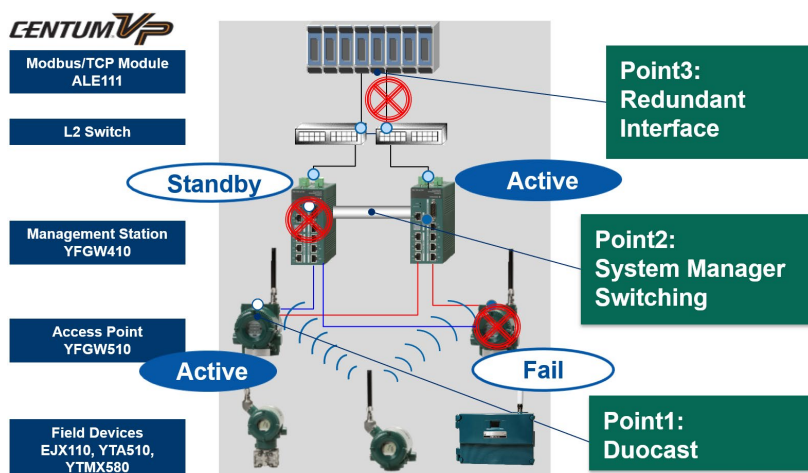

Yokogawa Full Redundant System

• Sky Mesh

A breakthrough method to increase reliable and optimize networks with 2.4GHz wireless communication, being suitable for plants and other locations. It supports long distance communication in trunk communication path, covering lots of IO with less routing devices, resulting to economical wireless network topologies.

• Battery pack

Replaceable in hazardous area, max 10-year battery life depending on operating condition.



Yokogawa Electric Corporation

YOKOGAWA ELECTRIC CORPORATION
9-32, Nakacho 2-chome, Musashino-shi, Tokyo 180-8750, Japan

YOKOGAWA CORPORATION OF AMERICA
12530 West Airport Blvd, Sugar Land, Texas 77478, USA

YOKOGAWA EUROPE B.V.
Euroweg 2, 3825 HD Amersfoort, The Netherlands

YOKOGAWA ENGINEERING ASIA PTE. LTD.
5 Bedok South Road, Singapore 469270, Singapore

YOKOGAWA MIDDLE EAST & AFRICA B.S.C.(c)
P.O. Box 10070, Manama, Building 577, Road 2516, Busaiteen 225, Muharraq, Kingdom of Bahrain

All Rights Reserved, Copyright©2017, Yokogawa Electric Corporation